



## HIGH-TECH WEAPONS OF THE HINDU GODS

by Robert Goodman ©1996

**T**he *Mahabharata* and the *Ramayana*, like almost all the great classics of India, describe many gods and demons. For the majority, these entities belong to the realms of mythology; but, for others, they are considered as real beings that existed in remote times. What is spoken about less, although mentioned in the above texts and the *Shastras* (Vedic science texts), is that these gods and demons possessed a variety of lethal weapons. Perhaps they were not divine but exceptional entities from this or some other planet.

### The Wars of the Gods

If we look in the *Srimad Bhagavatam* by Krishna Dvaipayana Vyasa, we find the detailed description of a tremendous battle between the god Krishna and the demon Banasura, who at that time countered with the help of Shiva who commenced to fire his weapons at Krishna one by one without conquering him—thanks to Krishna neutralising them.

First of all, Krishna counteracted a *brahmastra* (similar to an atomic bomb) with a similar weapon, and a kind of "air-earth

missile" with another one of equal characteristics. When Shiva hurled his "hurricane-producing weapon" against Krishna, the latter neutralised it, unmoved by Shiva's new attempt to defeat him. The contest did not finish at this, so Shiva then used his "incendiary bomb" which Krishna again neutralised, this time with his "water bomb". The now angry Shiva then resorted to his personal weapon, the *pasupatastra*, which was subsequently destroyed by Krishna's *narayanaastra*. Krishna, taking advantage of a "lull in the storm", fired his "sleep-provoking weapon" at Banasura and Shiva, the latter becoming so lethargic that he refused to fight any longer.

At last, Krishna could fight against Banasura and his soldiers face to face. After a long and bloody battle, Shiva's allies left the battlefield, obliging the defeated god to use his ultimate deterrent, the *sivajvara*, a terrifying device that destroyed everything within its reach, producing temperatures 12 times greater than the Sun and whose shape (described as having three heads and three legs) reminds us of modern missiles with multiple heads and three tailfins. But not even this weapon could destroy Krishna, who neutralised it with his *narayanajvara* that released such an intense cold that the combination of the two opposite energies produced a tremendous explosion. The feroci-

ty of this battle was comparable to that of modern warfare, both for its destructive effects and for the variety of arms employed (no fewer than 10 are mentioned in the text).

But before considering if these arms were real or the imagination of the author of the *Mahabharata*, it is interesting to examine other Hindu texts. The *Mausola Parva*, for example, speaks about a death-ray that reduced entire armies to ashes in seconds and caused the hair and fingernails of any survivors to fall out. Even kitchen utensils broke for no apparent reason, birds' feathers turned white in very little time, and food became contaminated.

The effects of this ray remind us of those produced by the atomic and hydrogen bombs, cruelly dropped on Hiroshima and Nagasaki. Furthermore, another text, the *Drona Parva*, speaks about the launching of a shining projectile which, on falling to the ground, produced a thick mist in the sky, causing the "clouds" to "roar and spit" blood, while at the same time scorching the Earth's surface. Again, it seems that these descriptions are very similar to those of atomic explosions.

Among those researchers who claim that these stories are not legends we count Alexander Gorbovski, who, in his book, *Enigmas of Antiquity*, mentions a human skeleton found in India that had a very high

level of radioactivity—50 times greater than normal. This discovery seems to confirm the authenticity of the accounts in the *Mausola Parva* and *Drona Parva* texts.

Returning to the *Mahabharata* and its descriptions of battles, this time in chapters 168, 169 and 173 of one of its books, the *Vanaparvan*, the battle between Arjun and the *asuras* (demons) is mentioned:

"Arjun ascended to the heavens to obtain divine weapons from the celestial beings and learn how to use them. During his stay, Indra, Lord of the Heavens, ordered Arjun to destroy the *asuras'* army, consisting of thirty million demons living in fortresses in the depths of the seas. Indra, Lord of the Heavens, lent Arjun his own spacecraft, piloted by his able assistant Malati. The craft could also travel under the water. In the ensuing battle, the *asuras* caused terrible floods, but Arjun neutralised their efforts with a divine weapon, drying up all the water."

Previously, in Chapter 102 of the *Varnaparvan*, it is described how Arjun returned to the heavens with his amphibious flying machine and how he discovered a city that spun around its own axis in the middle of the space. This city was called Hiranyapura (the Golden City) and had been constructed by Brahma, but at the time was falling into the hands of the *asuras*. The next adventure entrusted to Arjun was to destroy Hiranyapura, but the *asuras* defended it with their potent weapons. The text relates:

"There was a terrible battle during which the city was violently thrown into space and then rocked from one side to the other. After a long struggle, Arjun launched a rocket, destroying the city and reducing it to smithereens, all of its pieces falling to Earth. The surviving *asuras* got up from among the ruins and continued fighting. But Arjun finished the battle, thanks to the potent *pasupata*. All the *asuras* were completely annihilated and Indra and the other gods welcomed Arjun as a great hero."

Such stories remind us of the battles developed in the film, *Star Wars*, except for the fact that the script was written 5,000 years ago.

In the opinion of Dileep Kumar Kanjilal, Professor of Sanskrit at the Institute of Sanskrit in Calcutta, the logical deduction that may be reached from these texts is that, thousands of years ago, the Earth must have known a civilisation with sufficient scientific knowledge to construct aircraft

and launch colonies into space. Such civilisations must have been destroyed by some unknown catastrophe, as recorded only in legends.

### Atlantis vs the Rama Empire

According to the North American association the Lemurian Fellowship, Atlantis and the Rama Empire reached their greatest degree of grandeur at the same time. Both cultures had developed an advanced technology, competing with each other and with other civilisations. They not only countered with *vimana* aircraft but also with arms resembling "fire balls", capable of destroying entire cities.

Another weapon, known as "Kapila's Gance", could reduce more than 50,000 men to ashes in seconds. Last, but not least, they possessed "flying lances" (rockets?) that could destroy fortified cities.

The Lemurian Fellowship believes that when both cultures reached their zenith, war broke out between the people of Atlantis and the Rama Empire. The Atlanteans, determined to conquer the world and destroy their opponents at any cost, marched against the less-prepared Rama Empire and, on three occasions, invited its people to surrender. Three times the latter refused, obliging the Atlanteans to invade India.

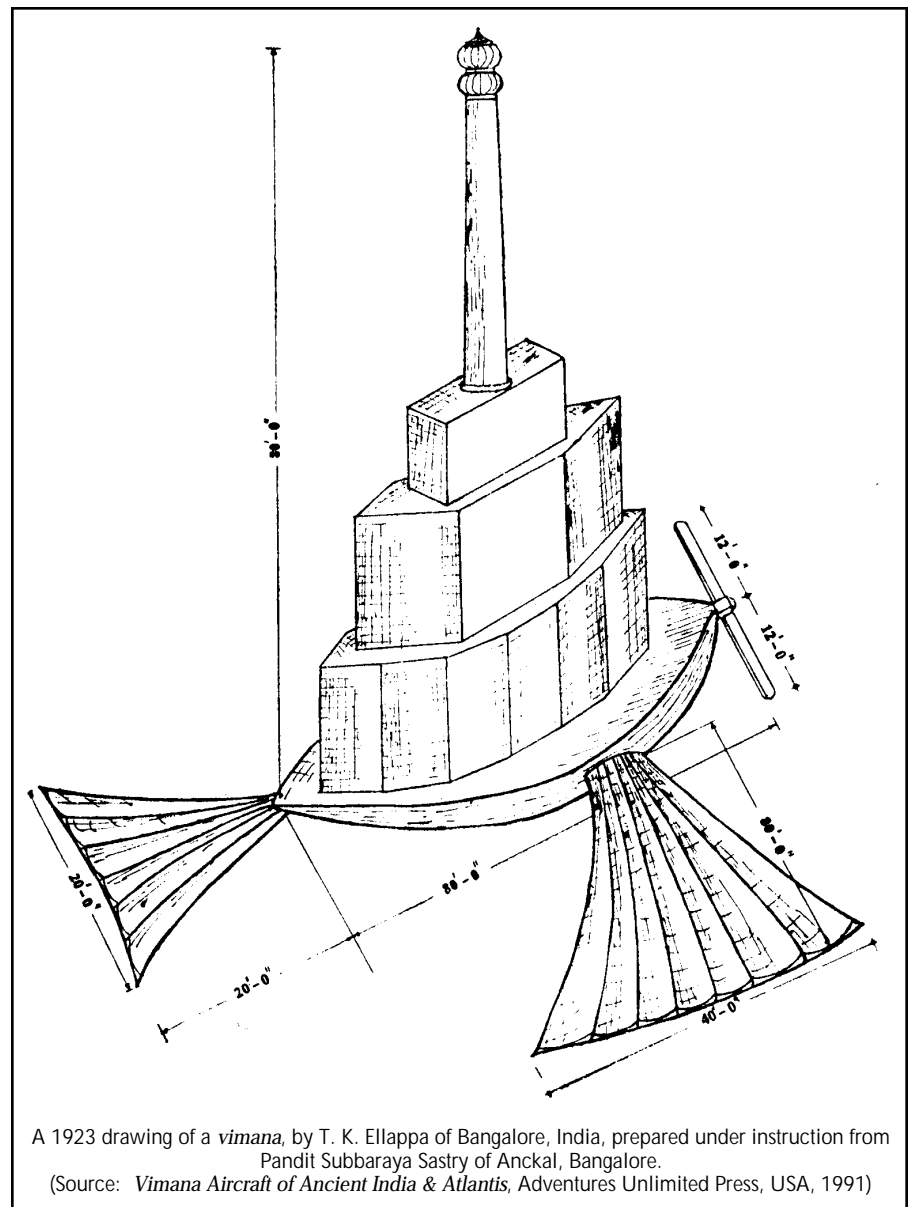

When Rama saw how the Atlantean soldiers marched towards the capital of his Empire, he raised his arms to the sky and concentrated the entire power of his mind—causing the general and all the officers of the Atlantean invasion to die on the spot. Without leaders, the Atlanteans were at a complete loss, so they returned to their aircraft and back to Atlantis.

This failure did not stop the Atlanteans. Throughout the *Mahabharata*, terrible scenes are narrated which Sanskrit scholars were unable to understand until the first atomic bombing of Japan.

### The Nine Unknown Men: Science Fiction or Secret Science?

There exists no modern state without a secret service entrusted with keeping large amounts of classified documents away from the public. If this is 'normal' nowadays, it is understandable that important information on technology would also have been strongly guarded in ancient civilisations. Hence, it is not strange that lay men and women of today know little about scientific developments of the ancient past. But this does not mean that such information has not been passed down from generation to generation over the centuries.

Returning to ancient India, between 274-232 BC the great Emperor Ashok created a secret society of scientists called the Nine Unknown Men. Each member of this society was entrusted with the task of writing about one science, continuously updating it and maintaining it in secret. According to

the French writers Louis Pawels and Jacques Bergier, the first of these books dealt with techniques of propaganda and psychological warfare; the second, physiological attacks and, specifically, how to kill an enemy without touching him; the third book considered microbiology as a potential source of weapons; the fourth, the transmutation of metals; the fifth dealt with the study of different forms of terrestrial and extraterrestrial communication; the sixth, the secrets of gravity and how to overcome it; the seventh, cosmogony; the eighth, light and its manipulation for warfare purposes; and the ninth dealt with sociology and determined rules for the evolution of societies, also foreseeing their possible decadence.'

In his book, *Vimana Aircraft of Ancient India and Atlantis*, David H. Childress asks if the sixth book mentioned above was really a text on *vimanas*, called the *Vymanika Sastra*, written by Maharshi Bharadwaja. This Shastra was discovered in 1919 and translated into English in 1972. The text contains detailed instructions on how to manufacture aircraft.

The defence systems described in these texts demonstrate that the ancient Hindu civilisation, whose leaders were considered to be divine beings or gods, indeed had possession of extremely advanced technology.

*(This article was first published in Mas Alla de la Ciencia [Monograph no. 17, June 1996], the Spanish journal dedicated to ancient technologies.)*

### THE MIRACLE STONES OF ALGECIRAS

by Robert Goodman ©1996

Healers have always been the target for study and even ridicule, but the particular case of a healer, Charo Alvarez, from the state of Cádiz in Spain, has attracted the interest not only of Spanish but also foreign journalists.

Until approximately seven years ago, Charo was a normal Spanish housewife, living in San Garcia, Algeciras, who had never been involved in any 'strange' circumstances and who would think twice before going to a healer.

In a recent conversation she told me her story. One fine day she awoke with an odd sensation: she was absolutely sure that she knew everything that was going to happen that day. Indeed, that same night she realised that everything had happened as she said it would. After this experience, she felt really worried and afraid. Until then, so-called paranormal phenomena were foreign to her and were something that happened to other people. Nevertheless, she gradually got used to her 'gift', and her premonitions continue right up to this day.

Charo then told me how she realised she was in telepathic communication with an entity from another dimension when she began receiving a series of messages leading her to what was going to become a new mission in her life: curing people. She explained that this mysterious 'spirit' identified itself as Sister Maria del Mar.

In Charo's own words: "I only have to think about her and she immediately establishes contact through automatic writing. At the beginning, Maria del Mar told me that near to my home there was a sacred site on a beach, full of very special stones that I had to find to be able to begin my mission of curing people. And the truth is, I found them. Later on, Maria del Mar taught me to communicate with the souls of incarnate persons through telepathy."

Charo told me that at first she did not know how she was going to become a healer as she had no idea whatsoever of anatomy, physiology or pathology of the human body that could serve as support for her new 'job'. But Maria del Mar told her not to worry as she would teach her how to connect with the different human organs and, above all, to find the stones.

### Safe sects

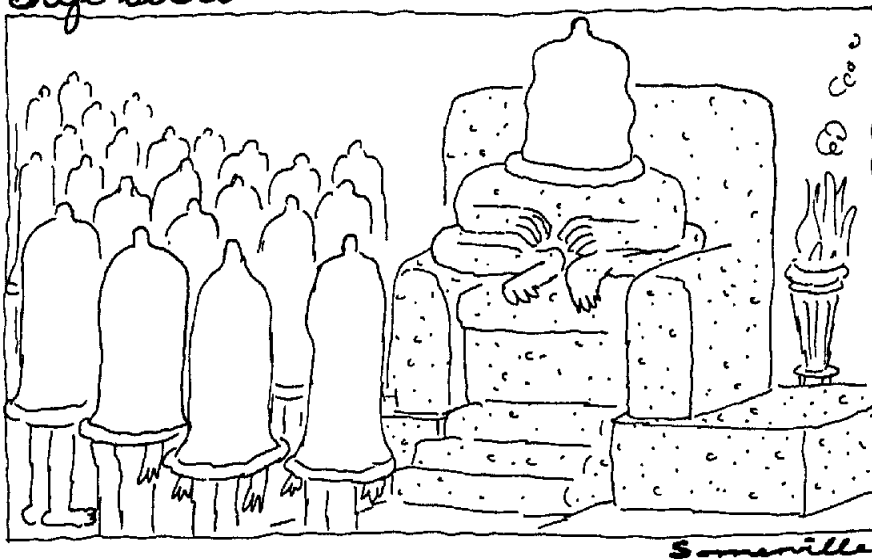

So Charo went to the local village beach of Chinarral where she found some stones with a strange characteristic: they had the shape of human organs. The most curious thing was that the edges of the different stones fitted into each other as if they were pieces of a jigsaw puzzle forming the entire human body. Moreover, on coming into contact with these stones, Charo felt that she was in contact with a real energy. From that day, Charo made many visits to the beach, supplying herself with stones and sea water—her 'instruments' of work as a healer.

She performs healings totally for free, not even accepting 'tips' from her patients. Her results are so spectacular that not a single day passes without dozens of people visiting her home in the hope of being cured from all types of illnesses.

When a patient visits Charo Alvarez for the first time, she invites him/her to sit in front of her on the other side of a table on which a volcanic rock has been placed. The patient then places his hands on this rock and closes his eyes while the healer recites some prayers. A few minutes afterwards, Charo already knows what is wrong with her patient and then gives him/her two healing stones and 2-3 litres of sea water. Apparently the treatment is identical for everybody. Each patient is instructed to take home the water and stones, place them in a suitable container and, during the following two weeks, rub the back of their hands with one of these 'magic' stones. And that's it.

One of the phenomena making this story different is the colour change of the water containing the stones. Apparently after eight or nine days of treatment, the sea water changes its crystalline blue colour to that of an opaque red or orange, resembling blood. To date, nobody has been able to explain this transformation, despite the water having been analysed in various Spanish and foreign laboratories.

Charo Alvarez has become so popular that her fame has crossed international frontiers. About a year ago, the English weekly, *Psychic News*, published an article about Charo Alvarez, with the title, "Spanish Healer's Sacred Stones Turn Blood-Red". The report provoked great interest in specialised circles—so much so that the director of Britain's Channel 4 TV program, *Schofield's Quest*, sent a film crew to Spain to look into the matter.

Charo Alvarez was interviewed and

filmed at her home by the television crew. Before returning to England, the reporter collected a sample of water that had been used in the cure of a patient and which apparently had taken on the colour of blood. The sample was sent to the chemical laboratories of the University of Birmingham for study. The interview as well as the preliminary results of the analysis were broadcast on *Schofield's Quest* on 3rd December 1995.

The results were quite disturbing, for the phenomenon in question had no explanation whatsoever. It could only be reported that the liquid contained a high concentration of amino acids, some of human origin, as well as extraordinarily high concentrations of gold, silver and copper.

As the laboratory analysis was non-conclusive, I thought it would be interesting to know Charo Alvarez's opinion.

**Robert Goodman (RG):** What relationship exists between the stones you use and the sea water?

**Charo Alvarez (CA):** I believe there is an exchange of positive and negative energies between the stones and the water. While the stones absorb negative energy from the patient's body, the water positively 'recharges' the stone in a continuous cycle. Regarding the healing process, this occurs in the patient's mind which sends the correct orders to the entire body for it to function correctly. Healing the mind, heals the body.

**RG:** What is the composition of the

stones used in healing? Have they any special component?

**CA:** They are completely normal and I collect them from Chinarral Beach, quite near here. They are mainly of flint, commonly used by Stone Age man to make his tools. And, like him, I also use them as my own working tools, as important elements in the healing process. And this comparison makes sense because, in those times, mankind knew how to cure the mind through the stones—at least this is what Maria del Mar communicated to me. In fact, she wants to reveal the secrets of that civilisation through me.

**RG:** The water analysis done by Birmingham University indicates the presence of human residues. Do you think this is a proof that your sacred stones absorb the negative energy from your patients?

**CA:** I am completely convinced. A few days ago I received a letter from Sarah Edwards, of *Schofield's Quest*, who told me that many healers wrote to the program after the broadcast, informing her that they had also experienced similar changes of colour in the water they use in their own treatments. And it would seem that the change progressively occurs as the illness disappears—the intensity of the colour depending on the final state of health of the patient.

*(This is the abridged English-language version of an article first published in the Spanish journal, Mas Alla de la Ciencia, issue no. 89, May 1996.)*

